

Applied Biosystems 7900HT Micro Fluidic Card

Getting Started Guide

© Copyright 2003, Applied Biosystems. All rights reserved.

For Research Use Only. Not for use in diagnostic procedures.

Notice to Purchaser: Disclaimer of License

The Micro Fluidic Card is optimized for use in the Polymerase Chain Reaction (PCR) and 5' nuclease detection methods covered by patents owned by Roche Molecular Systems, Inc. and F. Hoffmann-La Roche Ltd. No license under these patents to use the PCR process or 5' nuclease detection methods is conveyed expressly or by implication to the purchaser by the purchase of this product. A license to use the PCR process for certain research and development activities accompanies the purchase of certain Applied Biosystems reagents when used in conjunction with an authorized thermal cycler, or is available from Applied Biosystems. Further information on purchasing licenses to practice the PCR process may be obtained by contacting the Director of Licensing, Applied Biosystems, 850 Lincoln Centre Drive, Foster City, California 94404 or at Roche Molecular Systems, Inc., 1145 Atlantic Avenue, Alameda, California 94501.

Notice to purchaser: Limited License

TaqMan® probes are covered by U.S. Patent 5,723,591 and foreign counterparts and patents pending owned by Applied Biosystems Corporation, and are covered by U.S. Patents 5,801,155 and 6,084,102 and foreign counterparts licensed to Applied Biosystems.

Micro Fluidic Card developed in collaboration with 3M Company.

Information in this document is subject to change without notice. Applied Biosystems assumes no responsibility for any errors that may appear in this document. This document is believed to be complete and accurate at the time of publication. In no event shall Applied Biosystems be liable for incidental, special, multiple, or consequential damages in connection with or arising from the use of this document.

Applied Biosystems and MicroAmp are registered trademarks of Applied Biosystems Corporation or its subsidiaries in the U.S. and/or certain other countries.

AB (Design), ABI PRISM, Applied Biosystems, and Assays-On-Demand are trademarks of Applied Biosystems Corporation or its subsidiaries in the U.S. and/or certain other countries.

AmpErase, AmpliTaq Gold, and TaqMan are registered trademarks of Applied Biosystems Corporation.

All other trademarks are the sole property of their respective owners.

Part Number 4319399 Rev. C

7/2003

Contents

Safety	1
Safety Alert Words	1
Chemical Hazard Warning	1
Chemical Safety Guidelines	1
About MSDSs	2
Obtaining MSDSs	2
Site Preparation and Safety Guide	3
Waste Disposal	3
How to Obtain Services and Support	3
Introduction	4
About the Getting Started Guide	4
About the Micro Fluidic Card	4
About Micro Fluidic Card Chemistry	5
Preventing Contamination	5
Process Flowchart	6
Materials and Equipment	7
Components and Storage Conditions	7
Ordering Additional Cards or Reagents	8
Items Required But Not Supplied	9
Notes About Micro Fluidic Card Experiments	12
About the Comparative C_T Method of Relative Quantification	12
Significance of the Calibrator Sample	12
Design Guidelines	12
Performing Reverse Transcription	13
Summary	13
Where You Are in the Procedure	13
Guidelines for Preparing RNA	14
Starting Amount of Total RNA	14
Storing cDNA	14
Preparing and Running the Micro Fluidic Cards (PCR)	15
Summary	15
Where You Are in the Procedure	15
Process Overview	16

Guidelines for Preparing the PCR Mix	17
Amount of cDNA in the PCR Mix	17
Preparing the Sample-Specific PCR Mix	17
Guidelines for Loading Cards and Operating the Centrifuge	19
Creating Micro Fluidic Card Documents	20
Performing the Micro Fluidic Card Run	26
Performing Real-Time Data Analysis	29
Summary	29
Where You Are in the Procedure	29
Absolute vs. Relative Quantification	30
Additional Tasks Related to Micro Fluidic Card Use	31
References	32
Appendix A Micro Fluidic Card Information CD	33
About the Micro Fluidic Card Information CD	33
Assay Information File	33
Card Map Files	36
SDS Setup File	37
Index	39

Safety

Safety Alert Words

Four safety alert words appear in Applied Biosystems user documentation. Each word implies a particular level of observation or action, as described below:

IMPORTANT! Indicates information that is necessary for proper instrument operation, accurate chemistry kit use, or safe use of a chemical.



CAUTION Indicates a potentially hazardous situation that, if not avoided, can result in minor or moderate injury. It can also alert against unsafe practices, damage to an instrument, or loss of data.



WARNING Indicates a potentially hazardous situation that, if not avoided, can result in serious injury or death.



DANGER Indicates an imminently hazardous situation that, if not avoided, will result in serious injury or death. This signal word is to be limited to the most extreme situations.

Chemical Hazard Warning



WARNING CHEMICAL HAZARD. Some of the chemicals used with Applied Biosystems instruments and protocols are potentially hazardous and can cause injury, illness, or death.

Chemical Safety Guidelines

To minimize the hazards of chemicals:

- Read and understand the MSDSs provided by the chemical manufacturer before you store, handle, or work with any chemicals or hazardous materials. See [“About MSDSs.”](#)
- Minimize contact with chemicals. When handling chemicals, wear appropriate personal protective equipment such as safety glasses, gloves, and protective clothing. For additional safety guidelines, consult the MSDS.
- Minimize the inhalation of chemicals. Do not leave chemical containers open. Use only with adequate ventilation (for example, a fume hood). For additional safety guidelines, consult the MSDS.

-
- Check regularly for chemical leaks or spills. If a leak or spill occurs, follow the cleanup procedures recommended in the MSDS.
 - Comply with all local, state/provincial, or national laws and regulations related to chemical storage, handling, and disposal.

About MSDSs

Chemical manufacturers supply current Material Safety Data Sheets (MSDSs) with shipments of hazardous chemicals to *new* customers. They also provide MSDSs with the first shipment of a hazardous chemical to a customer after an MSDS has been updated. MSDSs provide the safety information you need to store, handle, transport, and dispose of the chemicals safely.

Each time you receive a new MSDS packaged with a hazardous chemical, be sure to replace the appropriate MSDS in your files.

Obtaining MSDSs

You can obtain from Applied Biosystems the MSDS for any chemical supplied by Applied Biosystems. This service is free and available 24 hours a day.

To obtain MSDSs:

1. Go to <https://docs.appliedbiosystems.com/msdssearch.html>.
2. In the Search field, type in the chemical name, part number, or other information that appears in the MSDS of interest. Select the language of your choice, then click **Search**.
3. Find the document of interest, right-click the document title, then select any of the following:
 - **Open** – To view the document
 - **Print Target** – To print the document
 - **Save Target As** – To download a PDF version of the document to a destination that you choose
4. To have a copy of a document sent by fax or e-mail, select **Fax** or **Email** to the left of the document title in the Search Results page, then click **RETRIEVE DOCUMENTS** at the end of the document list.
5. After you enter the required information, click **View/Deliver Selected Documents Now**.

Site Preparation and Safety Guide

A site preparation and safety guide is a separate document sent to all customers who have purchased an Applied Biosystems instrument. Refer to the guide written for your instrument for information on site preparation, instrument safety, chemical safety, and waste profiles.

Waste profiles help you plan for the handling and disposal of waste generated by operation of the instrument. Read the waste profiles and all applicable MSDSs for your instrument before handling or disposing of chemical waste.

Waste Disposal

If potentially hazardous waste is generated when you operate the instrument, you must:

- Characterize (by analysis if necessary) the waste generated by the particular applications, reagents, and substrates used in your laboratory.
- Ensure the health and safety of all personnel in your laboratory.
- Ensure that the instrument waste is stored, transferred, transported, and disposed of according to all local, state/provincial, and/or national regulations.

Note: Radioactive or biohazardous materials may require special handling, and disposal limitations may apply.

How to Obtain Services and Support

For the latest services and support information for all locations, go to <http://www.appliedbiosystems.com>, then click the link for **Services and Support**.

At the Services and Support page, you can:

- Search through frequently asked questions (FAQs)
- Submit a question directly to Technical Support
- Order Applied Biosystems user documents, MSDSs, certificates of analysis, and other related documents
- Download PDF documents
- Obtain information about customer training
- Download software updates and patches

In addition, the Services and Support page provides access to worldwide telephone and fax numbers to contact Applied Biosystems Technical Support and Sales facilities.

Introduction

About the Getting Started Guide

This guide accompanies the Micro Fluidic Card. It provides instructions for the preparation, execution, and analysis of Micro Fluidic Card experiments.

If you are familiar with the theory behind the Applied Biosystems 7900HT Micro Fluidic Card (Micro Fluidic Card) chemistry or the ABI PRISM® 7900HT Sequence Detection System (7900HT system) data collection, the information in this document serves as a quick reference guide for conducting experiments using the Micro Fluidic Card.

If this is the first time you are using the Micro Fluidic Card, this guide refers you to the appropriate sections of the *ABI PRISM® 7900HT Sequence Detection Systems and SDS Enterprise Database User Guide* (PN 4317596, referred to as the user guide for the 7900HT system throughout the rest of this document) for more information.

Note: A copy of the user guide is shipped with the 7900HT system. An electronic copy is included on the Micro Fluidic Card Information CD that comes with your Micro Fluidic Card order.

About the Micro Fluidic Card

The Micro Fluidic Card allows you to use the 7900HT system for profiling gene expression using the Comparative C_T Method of relative quantification. The card evaluates from one to eight cDNA samples or controls generated from total RNA in a two-step RT-PCR experiment.

Key Features

Following are the key features of the Applied Biosystems 7900HT Micro Fluid Card:

- Assays-on-Demand™ Gene Expression Products for all real-time RT-PCR applications
- Flexible card format handles multiple sample/target combinations
- Small-volume design minimizes sample and reagent consumption
- Streamlined reaction set-up saves time and reduces labor-intensive steps

- Provides access to high-throughput, 384-well format without liquid-handling robotics
- Micro Fluidic Cards, when used with the 7900HT system, detect 2-fold discrimination at the 99.7% confidence level

More Information About Micro Fluidic Cards

Chapter 4 of the user guide for the 7900HT system contains more information about the Micro Fluidic Card, including

- How it works – The Micro Fluidic Card functions as an array of reaction vessels for the PCR/sequence detection step.
- Card components – Each card is a specially developed 384-well consumable divided into eight sets of assays.
- Internal Structure – Micro Fluidic Cards have fill reservoirs, or ports, into which you load your samples.
- Detectors – Micro Fluidic Cards permit the amplification of the endogenous control and targets in cDNA samples using fluorogenic 5' nuclease assays.

Note: Real-time PCR in Micro Fluidic Cards are run as singleplex reactions.

About Micro Fluidic Card Chemistry

Micro Fluidic Card experiments use a two-step RT-PCR process. In the reverse-transcription (RT) step, cDNA is reverse transcribed from total RNA samples using random primers from the High Capacity cDNA Archive Kit. Additional details about the RT-PCR process are contained in the High Capacity cDNA Archive Kit Protocol (PN 4322169).

In the PCR step, PCR products are synthesized from cDNA samples using the TaqMan Universal PCR Master Mix. The PCR step employs the 5' nuclease assay, which is described in Appendix C of the user guide for the 7900HT system.

Preventing Contamination

PCR assays require special laboratory practices to avoid false positive amplifications (Kwok and Higuchi, 1989). The high throughput and repetition of these assays can lead to amplification of a single DNA molecule (Saiki *et al.*, 1985; Mullis and Faloona, 1987).

For more information about preventing contamination, refer to Chapter 4 of the user guide for the 7900HT system.

Process Flowchart

The following diagram provides an overview of the Micro Fluidic Card process.

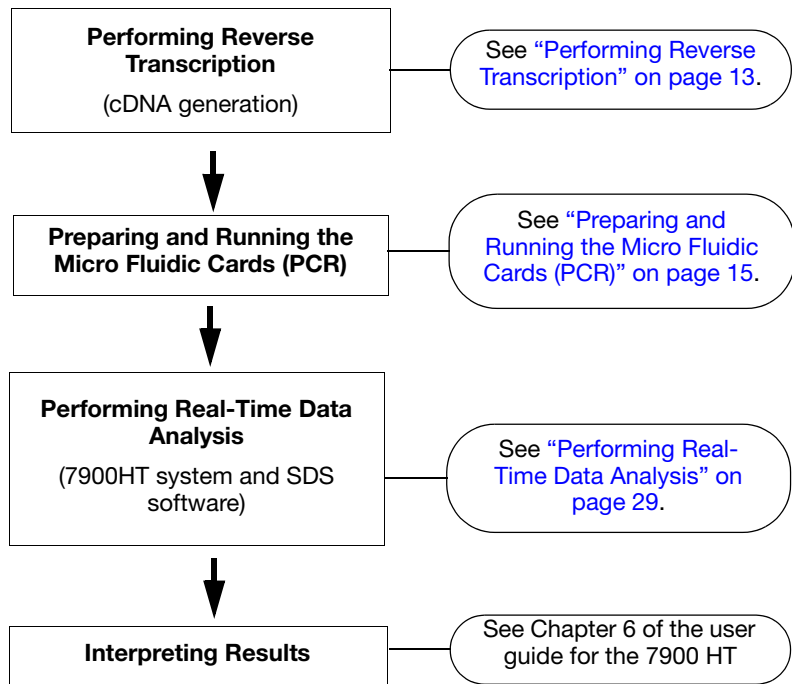

Materials and Equipment

Components and Storage Conditions

The Micro Fluidic Card Upgrade consists of two kits, the 7900HT Micro Fluidic Card Hardware Upgrade Kit (PN 4329012) and the 7900HT Micro Fluidic Card Chemical Installation Kit (PN 4340090). The following tables list the components of each kit and, where applicable, their storage conditions. The tables also list the part numbers for kit components that are available for individual purchase.

All Micro Fluidic Cards ship at ambient temperature. Store Micro Fluidic Cards at the recommended temperature upon receipt.

7900HT Micro Fluidic Card Hardware Upgrade Kit (PN 4329012)

Component	Part Number
<i>Applied Biosystems 7900HT Micro Fluidic Card Getting Started Guide</i>	4319399
Micro Fluidic Card Sample Block (Also referred to as the thermal cycler module or thermal block)	4329011
Micro Fluidic Card Sealer	–
Sorvall/Heraeus Custom Buckets and Adaptors (4 pcs.)	–
7900HT Heated Cover	–
SDS 2.1 Software CD	–

7900HT Micro Fluidic Card Chemical Installation Kit (PN 4340090)

Component	Part Number	Storage
Calibration Micro Fluidic Card (2 pcs.)	–	ambient
Installation Micro Fluidic Card (12 pcs.) (Also referred to as the TGF- β Instrument Verification Card)	–	2–8 °C
Spectral Calibration Kit, 96-Well	4328639	-15 to -25 °C

Component	Part Number	Storage
Spectral Calibration Kit, 384-Well	4323977	-15 to -25 °C
Spectral Calibration Reagent Kit	–	-15 to -25 °C
TaqMan® Human Raji cDNA (25ng/μL)	–	-15 to -25 °C
TaqMan® Universal PCR Master Mix	4304437	2–8 °C

Ordering Additional Cards or Reagents

To order additional Micro Fluidic Cards or reagents, visit the Applied Biosystems Web site at <http://www.appliedbiosystems.com>.

Micro Fluidic Cards are available in one of ten configurations:

Description	Part Number	Total Number of Targets	Number of Samples	Number of Assay Replicates Per Port
7900HT Gene Expression Micro Fluidic Card Configuration 1	4342247	12	8	4
7900HT Gene Expression Micro Fluidic Card Configuration 2	4342249	24	8	2
7900HT Gene Expression Micro Fluidic Card Configuration 3	4342251	24	4	4
7900HT Gene Expression Micro Fluidic Card Configuration 4	4342253	48	8	1
7900HT Gene Expression Micro Fluidic Card Configuration 5	4342255	48	4	2
7900HT Gene Expression Micro Fluidic Card Configuration 6	4342257	48	2	4
7900HT Gene Expression Micro Fluidic Card Configuration 7	4342259	96	4	1
7900HT Gene Expression Micro Fluidic Card Configuration 8	4342261	96	2	2

Description	Part Number	Total Number of Targets	Number of Samples	Number of Assay Replicates Per Port
7900HT Gene Expression Micro Fluidic Card Configuration 9	4342263	96	1	4
7900HT Gene Expression Micro Fluidic Card Configuration 10	4342265	380	1	1

The 7900HT Immune Profiling Micro Fluidic Card (PN 4342510), which facilitates the analysis of gene expression targets known to have implications in immune response, is also available.

Items Required But Not Supplied

In addition to the components supplied with the Micro Fluidic Card, other items are required for this protocol. As noted below, some of the items listed are available from major laboratory suppliers (MLS).

Note: You need only one of the eight centrifuges and one of the two rotors listed in the table.

Instruments and Accessories

Item	Source	Part Number
ABI PRISM® 7900HT Sequence Detection System	Applied Biosystems	Contact Applied Biosystems
Applied Biosystems 7900HT Micro Fluidic Cards	Applied Biosystems	Contact Applied Biosystems
High Capacity cDNA Archive Kit	Applied Biosystems	4322171
TaqMan® Universal PCR Master Mix ^a	Applied Biosystems	4304437
Microcentrifuge	MLS	---

One of the following centrifuges: ^{b,c}		
Sorvall® Legend T Centrifuge (EASYSer) nonrefrigerated tabletop centrifuge	Kendro Fisher Scientific	75004367
Sorvall® Legend T (QUIKSet) nonrefrigerated tabletop centrifuge	Kendro Fisher Scientific	75004366
Heraeus Multifuge 3S (EASYSer) nonrefrigerated tabletop centrifuge	Cardinal Health	75004365
Heraeus Multifuge 3L (QUIKSet) nonrefrigerated tabletop centrifuge	Cardinal Health	75004364
Sorvall® Legend RT (EASYSer) refrigerated tabletop centrifuge	Kendro Fisher Scientific	75004377
Sorvall® Legend RT (QUIKSet) refrigerated tabletop centrifuge	Kendro Fisher Scientific	75004376
Heraeus Multifuge 3SR (EASYSer) refrigerated tabletop centrifuge	Cardinal Health	75004375
Heraeus Multifuge 3LR (QUIKSet) refrigerated tabletop centrifuge	Cardinal Health	75004374
One of the following rotors: ^d		
4-Place Swinging Bucket Rotor Requires tool (included) for securing to centrifuge.	Kendro Fisher Scientific Cardinal Health	75006445
4-Place Swinging Bucket Rotor Twist-on fixture. Does not require tool for securing to centrifuge.	Kendro Fisher Scientific Cardinal Health	75006434

- a. The TaqMan Universal PCR Master Mix (5 mL) is 2X in concentration and contains sufficient reagent for approximately 12 Micro Fluidic Cards. The mix is optimized for TaqMan reactions and contains AmpliTaq Gold® DNA Polymerase, AmpErase® UNG, dNTPs with dUTP, Passive Reference, and optimized buffer components.
- b. All centrifuges have digital displays. The user interface either has a membrane touchpad (for EASYSer models) or is knob-activated (for QUIKSet models). Rotors and other accessories are not included with the centrifuge.
- c. The centrifuge part numbers provided in the table are for North America only.
- d. Rotors do not include buckets. Both rotors accept the Sorvall/Heraeus Custom Buckets and Adaptors (4 pcs.) that come with the 7900HT Micro Fluidic Card Hardware Upgrade Kit (PN 4329012).

Lab Equipment and Materials

Item	Source	Part Number
MicroAmp® Reaction Tubes with Caps, 0.2-mL	Applied Biosystems	N8010612
Rainin F-100 micropipette (fixed 100- μ L volume) ^a	Rainin	F-100
Rainin Fine Point pipette tips (100- μ L) ^a	Rainin	HR-100F
Gloves, disposable, powder-free	MLS	---
Microcentrifuge tubes, sterile 1.5-mL	MLS	---
Water, RNase/DNase-free, deionized	MLS	---
Scissors	---	---

a. Applied Biosystems recommends Rainin pipettes and tips; however, you may determine that other brands are equivalent.

Notes About Micro Fluidic Card Experiments

About the Comparative C_T Method of Relative Quantification

Relative gene expression values can be obtained from 7900HT system data using the Comparative C_T Method for relative quantification. In the Comparative C_T Method, quantity is expressed relative to a calibrator sample that is used as the basis for comparative results. Therefore, the calibrator is the 1 \times sample and all other quantities are expressed as an n -fold difference relative to the calibrator.

Note: For more information on the Comparative C_T Method for relative quantification, refer to Livak & Schmittgen, 2001 and the *ABI PRISM[®] 7700 Sequence Detection System User Bulletin #2: Relative Quantitation of Gene Expression* (PN 4303859).

Significance of the Calibrator Sample

All Micro Fluidic Card relative quantification experiments require data from a calibrator sample. During analysis, the ABI PRISM[®] 7900HT Sequence Detection System software (SDS 2.1 software) calculates the levels of target gene expression in samples relative to the level of expression in the calibrator. Thus, the calibrator sample is an integral part of the relative quantification calculation because it serves as the basis for the comparative results.

Examples of possible calibrator samples include:

- A zero timepoint sample in a time-course experiment
- An untreated sample (versus treated samples)
- A resting sample (versus activated samples)

Design Guidelines

The most important factor to consider when designing Micro Fluidic Card experiments is how you intend to analyze your data:

- If you want to analyze your data using Applied Biosystems RQ Manager Software, set up relative quantification plate documents. (This is the recommended method.)
- If you want to analyze your data using a custom application, set up absolute quantification plate documents.

IMPORTANT! Once you have set up a relative quantification document, you cannot convert it into an absolute quantification document. Similarly, you cannot convert an absolute quantification document into a relative quantification document. (For more information, see Chapter 6 of the user guide for the 7900HT system.)

Performing Reverse Transcription

Summary Synthesis of cDNA from total RNA samples using the High Capacity cDNA Archive Kit (PN 4322171) is the first step in the two-step RT-PCR gene expression quantification experiment.

Use the manual method for converting total RNA into cDNA, as specified in the *High Capacity cDNA Archive Kit Protocol* (PN 4322169).

Note: The protocol is not shipped with the High Capacity cDNA Archive Kit. You must download the protocol from the Applied Biosystems Documents on Demand Web site at

<http://docs.appliedbiosystems.com/search.taf>

To search for the document, select ABI PRISM™ 6100 Nucleic Acid PrepStation under Products and click **Search**. The protocol is listed under the Protocols heading.

Where You Are in the Procedure

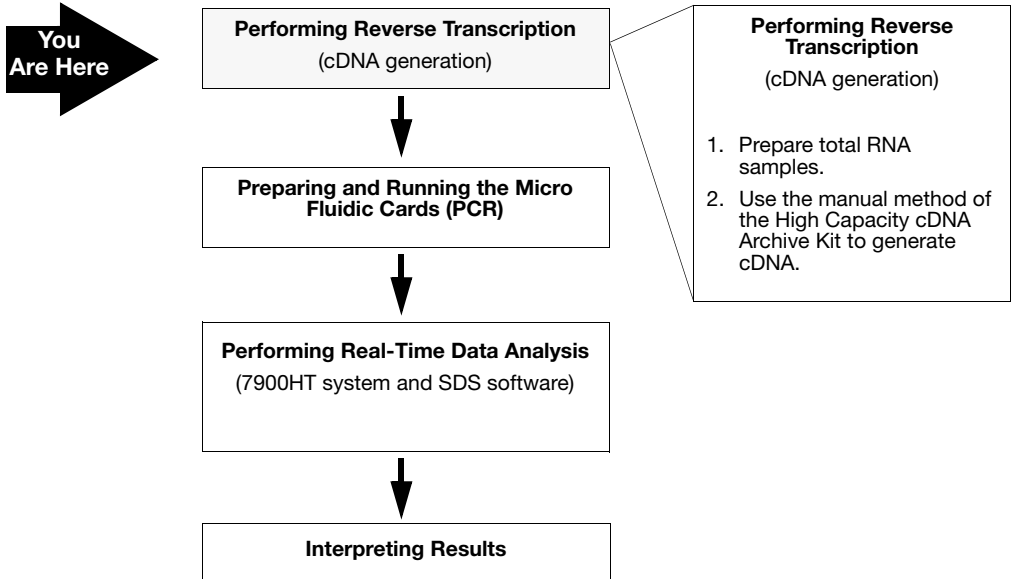

Guidelines for Preparing RNA

Use only total RNA samples to generate cDNA for use with the Micro Fluidic Card. The 18S RNA endogenous control assay cannot accurately evaluate cDNA generated from poly A⁺ RNA samples because most of the rRNA has been removed from them.

IMPORTANT! See the Applied Biosystems product insert included with your reagent kit for specific information on the recommended template for use with the kit.

The *High Capacity cDNA Archive Kit Protocol* (PN 4322169) also contains additional guidelines for preparing the RNA template.

Starting Amount of Total RNA

The starting amount of total RNA that you need to convert to cDNA depends on which Micro Fluidic Card Configuration you intend to use. For example, Configuration 1 allows you to load eight different samples into the eight fill reservoirs on the card, whereas Configuration 10 requires you to load the same sample into all eight fill reservoirs on the card. Refer to the assay information file (AIF) on the Micro Fluidic Card Information CD to confirm the number of fill reservoirs per sample.

Based on guidelines for Micro Fluidic Cards (discussed in [“Amount of cDNA in the PCR Mix” on page 17](#)), you should load between 1–100 ng of total RNA converted to cDNA per fill reservoir.

Storing cDNA

After thermal cycling, store all cDNA samples at -15 to -25 °C. To minimize repeated freeze-thaw cycles of cDNA, Applied Biosystems recommends that you store your cDNA samples in aliquots.

Preparing and Running the Micro Fluidic Cards (PCR)

Summary Amplification of cDNA is the second step in the two-step RT-PCR experiment. In this step, the sample-specific PCR mix is loaded into a Micro Fluidic Card. The Micro Fluidic Card is run on the 7900HT system, where AmpliTaq Gold[®] DNA polymerase amplifies the cDNA synthesized from the original total RNA sample.

Where You Are in the Procedure

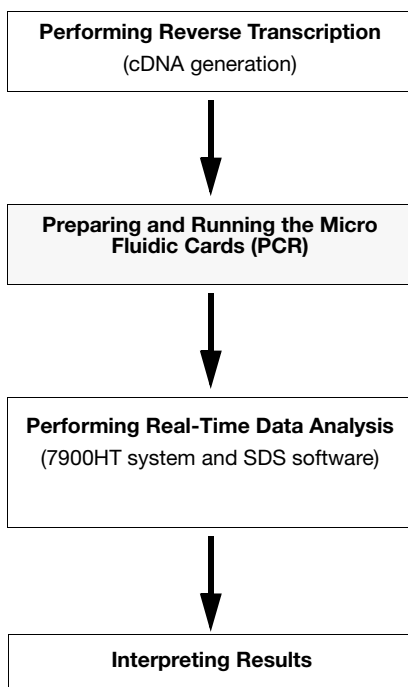

Loading, Centrifuging, Sealing, Trimming, and Running the Micro Fluidic Cards

1. Prepare the cDNA samples for the real-time PCR run (sample-specific PCR mix).
2. Pipette the sample-specific PCR mix into a Micro Fluidic Card.
3. Centrifuge the Micro Fluidic Card.
4. Seal the Micro Fluidic Card and trim-off fill reservoirs.
5. Create a Micro Fluidic Card document.
 - If you are using SDS 2.1 Software to analyze results, create a relative quantification document.
 - If you are using custom software to analyze results, create an absolute quantification document.
6. Perform the run.

Process Overview

The PCR process consists of the following procedures:

1.	Preparing the sample-specific PCR mix. See page 17 .
2.	Loading the Micro Fluidic Cards. See Chapter 4 of the user guide for the 7900HT system.
3.	Centrifuging the Micro Fluidic Cards. See Chapter 4 of the user guide for the 7900HT system and page 19 for Micro Fluidic Card-specific guidelines on centrifuge operation.
4.	Sealing the Micro Fluidic Cards and trimming-off fill reservoirs. See Chapter 4 of the user guide for the 7900HT system. IMPORTANT! The sealing process is unidirectional. Once you go over the card in one direction, you cannot reverse the process. Note: Sealing tape is not required for the card sealer. The sealer makes grooves into the foil side of the card, sectioning off the sample pocket from the main channel.
5.	Creating Micro Fluidic Card Documents. See page 20 .
6.	Performing Micro Fluidic Card Runs. See page 26 .

Guidelines for Preparing the PCR Mix

Follow these guidelines to ensure optimal PCR performance.

- Do not remove a Micro Fluidic Card from its packaging until the packaging has reached room temperature and you are ready to load it with sample-specific PCR mix. Prolonged exposure to indoor lighting can photo-degrade the fluorescent probes contained within the Micro Fluidic Card. Do not expose the Micro Fluidic Card to sunlight.
- Load each Micro Fluidic Card fill reservoir with sample-specific PCR mix made from a single cDNA sample.
- Load 100 μ L of the sample-specific PCR mix per fill reservoir to ensure adequate filling. Smaller volumes will result in insufficiently filled Micro Fluidic Cards.
- Do not add additional sample to partially filled Micro Fluidic Cards. When you centrifuge the card, the sample-specific PCR mix resuspends the dried TaqMan[®] probes and primers within the wells of the Micro Fluidic Card. Adding sample after centrifuging disrupts the resuspended assay positions.

Amount of cDNA in the PCR Mix

Each 100- μ L PCR mix should contain 1 ng to 100 ng of total RNA converted to cDNA. The cDNA sample volume, with added water or Tris-EDTA buffer, should be 50 μ L.

Note: 1 ng to 100 ng is the recommended range. Micro Fluidic Cards can accept between 0.1 ng to 1 μ g of total RNA converted to cDNA per port. At less than 1 ng per fill reservoir, however, rare messages can be difficult to detect.

Preparing the Sample-Specific PCR Mix

IMPORTANT! Load only one sample-specific PCR mix (cDNA sample + RNase/DNase-free water + TaqMan[®] Universal PCR Master Mix) per fill reservoir.



CAUTION CHEMICAL HAZARD. TaqMan Universal PCR Master Mix may cause eye and skin irritation. Exposure may cause discomfort if swallowed or inhaled. Read the MSDS, and follow the handling instructions. Wear appropriate protective eyewear, clothing, and gloves.

To prepare the sample-specific PCR mix:

1.	Label a 1.5-mL microcentrifuge tube.										
2.	Remove a cDNA sample from the freezer. Thaw the sample by rolling it between your fingers.										
3.	Gently vortex the sample, then centrifuge the tube.										
4.	<p>Add the following components to the labeled 1.5-mL microcentrifuge tube:</p> <table border="1"> <thead> <tr> <th>Component</th> <th>Volume Per Fill Reservoir (μL)</th> </tr> </thead> <tbody> <tr> <td>cDNA sample^a (from step 2)</td> <td>5</td> </tr> <tr> <td>RNase/DNase-free water</td> <td>45</td> </tr> <tr> <td>TaqMan[®] Universal PCR Master Mix (2X)</td> <td>50</td> </tr> <tr> <td>Total</td> <td>100</td> </tr> </tbody> </table> <p>a. Total RNA converted to cDNA. The cDNA sample volume can vary (up to 50 μL) to achieve a specific sample amount (in nanograms). Water is added to achieve a total volume of 50 μL for sample and water.</p>	Component	Volume Per Fill Reservoir (μL)	cDNA sample ^a (from step 2)	5	RNase/DNase-free water	45	TaqMan [®] Universal PCR Master Mix (2X)	50	Total	100
Component	Volume Per Fill Reservoir (μL)										
cDNA sample ^a (from step 2)	5										
RNase/DNase-free water	45										
TaqMan [®] Universal PCR Master Mix (2X)	50										
Total	100										
5.	Cap the microcentrifuge tube and thoroughly mix the solution by gentle vortexing.										
6.	Centrifuge the tube to eliminate air bubbles from the mixture.										
7.	<p>Continue with Loading the Micro Fluidic Cards as described in Chapter 4 of the user guide for the 7900HT system.</p> <p>Refer to the guidelines for loading cards and operating the centrifuge below.</p>										

Guidelines for Loading Cards and Operating the Centrifuge

After the fill reservoirs of a Micro Fluidic Card have been loaded with the sample-specific PCR mix, the centrifuge system distributes the PCR mix into the wells of the card. Refer to Chapter 4 of the user guide for the 7900HT system for information about loading the centrifuge. Following are additional guidelines about loading Micro Fluidic Cards:

- Install SDS 2.1 software on all instruments devoted to running Micro Fluidic Cards.
- Load each Micro Fluidic Card with sample-specific PCR mix.
- Run Micro Fluidic Cards within 64 hours of loading them.

To ensure a high degree of reproducibility, Applied Biosystems recommends scheduling your runs so that each Micro Fluidic Card is run as soon as possible. After sealing, there is no measurable well-to-well contamination for up to 64 hours.

Sorvall Legend and Heraeus centrifuges have either a touchpad control (EASYSets models) or knob-operated control panel (QUIKSet models). Both centrifuges use the same bucket type and adaptor. The following table lists the operational parameters for Micro Fluidic Cards.

Parameter	QUIKSet	EASYSets
Up ramp rate	3	9
Down ramp rate	N/A	9
Rotational speed	1200 rpm	1200 rpm
Centrifugation time	2 × 1 min (0.01 on display)	2 × 1 min (0.01 on display)

IMPORTANT! Do not exceed 1200 rpm or accumulated centrifuge times of more than 3 min. Excessive centrifugation speeds and times may deform Micro Fluidic Cards.

Creating Micro Fluidic Card Documents

About Micro Fluidic Card Documents

To run a Micro Fluidic Card on the 7900HT system, you need the ABI PRISM® 7900HT Sequence Detection System software (SDS 2.1 software) and a Micro Fluidic Card document (also called an SDS or plate document). The 7900HT system uses the SDS document to organize and store the fluorescence data gathered during the PCR run.

Each SDS document (*.sds) stores information about a unique consumable (in this case, a Micro Fluidic Card with a unique barcode), including:

- Plate type
- Detector setup
- Target/sample configurations
- Thermal cycling parameters
- Data collection parameters
- Raw data gathered during the PCR process

There are two types of SDS documents for real-time PCR runs: absolute quantification (AQ) and relative quantification (RQ). Use the appropriate document type for your analysis, as described in [“Design Guidelines” on page 12](#). Chapter 6 of the user guide for the 7900HT system contains more information about relative and absolute quantification.

Setting up documents as RQ documents allows you to use Applied Biosystems RQ Manager software for automated data analysis. This software does not support analysis of AQ documents. Applied Biosystems recommends that you use relative quantification to analyze Micro Fluidic Cards. Chapter 6 of the user guide for the 7900HT system contains more information about setting up relative quantification documents for the first time.

IMPORTANT! When creating SDS documents, make sure you create a document type (AQ or RQ) that is consistent with the type of analysis for your study. You cannot readily convert RQ documents to AQ documents, nor can you convert AQ documents to RQ documents.

About Micro Fluidic Card Templates

SDS template documents (*.sdt) contain the same information as SDS documents, but do not store raw data. You can use templates to create duplicate plate documents for a series of plates with identical configurations.

Using the SDS Setup File to Generate SDS Templates

When you order a custom Micro Fluidic Card, the accompanying Micro Fluidic Card Information CD contains an SDS setup file. The setup file contains the following information that is specific to your custom Micro Fluidic Card:

- Detector – Indicates the gene symbol and Applied Biosystems assay number
- Reporter – Indicates the reporter dye
- Task – Indicates the task of the well (Endogenous Control, Target, Unknown, Standard, or NTC)

Instead of entering the above information manually for each assay, SDS software allows you to import the information from the setup file, saving time and effort. You can then save the file as an SDS document (*.sds) or an SDS template (*.sdt).

Note: Appendix A contains additional information about the SDS setup file and other contents of the Micro Fluidic Card Information CD.

The following procedure explains how to use the SDS setup file to create a Micro Fluidic Card template or document for relative quantification.

Note: The procedure assumes that you have calibrated the 7900HT system by performing both background and pure dye runs for the Micro Fluidic Card. For more information about calibration, see Chapter 7 of the user guide for the 7900HT system.

To create a Micro Fluidic Card template or document for relative quantification using the SDS setup file:

1. Create a new document.
 - a. From the **File** menu, select **New**.
The New Document dialog box appears.
 - b. In the Assay field, select **Relative Quantification ($\Delta\Delta C_T$)**.

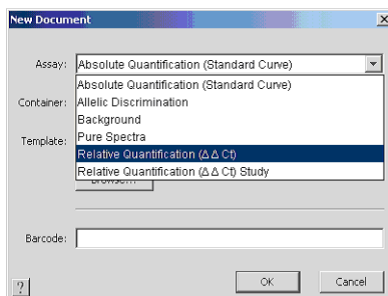

- c. In the Container field, make sure **384 Wells Card** is selected.
You do not need to specify a template in the Template field.

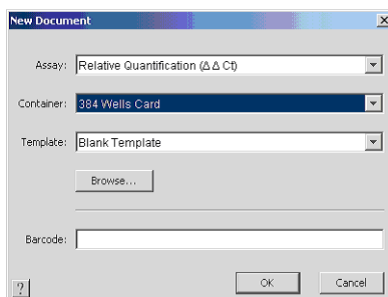

- d. Click **OK**.
The SDS 2.1 software opens a new SDS document of the type you selected in step 1b.

To create a Micro Fluidic Card template or document for relative quantification using the SDS setup file: *(continued)*

2. Import the contents of the SDS setup file into the current document.
 - a. Place the Micro Fluidic Card Information CD in the CD-ROM drive (typically, D: or E:)
 - b. From the **File** menu, select **Import**.
The Import dialog box appears.
 - c. In the Look In field, select the CD-ROM drive.

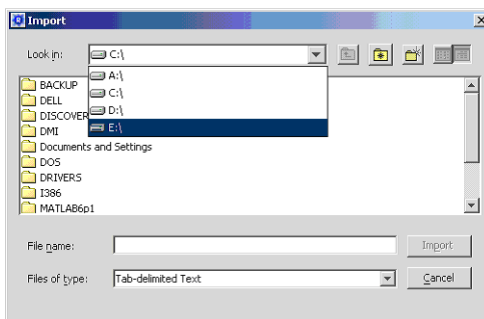

- d. Select the SDS setup file (*SDS_prodNum.txt*, where *prodNum* is the production number of your custom Micro Fluidic Card).

Note: Each custom Micro Fluidic Card is assigned a unique production number. This number appears as part of the file names of assay information file (AIF), cardmap, and SDS setup files.

IMPORTANT! Take care when modifying the contents of the setup file. Modifying the setup file can corrupt the information on the Micro Fluidic Card.

- e. Click **Import**.

The SDS 2.1 software imports the data from the setup file into the current SDS document. The detectors for each assay are assigned to the appropriate wells as indicated in the card map.

Note: The card map file is also provided on the Micro Fluidic Card Information CD. Refer to Appendix A or to the *readme.txt* file on the CD for more information about the card map file.

To create a Micro Fluidic Card template or document for relative quantification using the SDS setup file: (continued)

3. Select all wells.
4. Specify the task (Target or Endogenous Control) for each detector.

When you import the SDS setup file, mandatory controls are designated Endogenous Control; all other detectors are designated Target.

Note: SDS 2.1 software does not calculate the relative quantity for detectors designated as endogenous controls.

If you want to designate other detectors as endogenous controls:

- a. Select all wells by clicking the top left-hand corner of the plate view.
The entire plate is highlighted.
- b. Locate the Setup tab (right-hand side of your screen).
- c. In the Detector column, identify a gene symbol/Applied Biosystems assay number that serves as an endogenous control.
- d. Select the task for the detector by clicking in the Task column for the detector and selecting **Endogenous Control**.

Use	Detector	Reporter	Task	Color
<input type="checkbox"/>	4342376-GAPDH	FAM	Endogenous Control	Red
<input type="checkbox"/>	CD44-Hs00174139_m1	FAM	Target	Blue
<input checked="" type="checkbox"/>	CD83-Hs00188486_m1	FAM	Target	Orange
<input type="checkbox"/>	CD86-Hs00199349_m1	FAM	Target	Cyan
<input type="checkbox"/>	COL1A2-Hs00164099_m1	FAM	Endogenous Control	Light Blue
<input type="checkbox"/>	COL6A1-Hs00242448_m1	FAM	Target	Dark Blue
<input type="checkbox"/>	CSF2-Hs00171266_m1	FAM	Target	Light Green
<input type="checkbox"/>	EGR1-Hs00152928_m1	FAM	Target	Light Green
<input type="checkbox"/>	FGF2-Hs00266645_m1	FAM	Target	Light Blue

- e. Change the task for the mandatory controls to Target.

Note: These changes apply only to the current analysis.

To create a Micro Fluidic Card template or document for relative quantification using the SDS setup file: (continued)

5.	<p>In the Instrument tab, make sure that the default thermal cycling conditions for Micro Fluidic Cards are set:</p> <table border="1" data-bbox="522 340 1232 586"> <thead> <tr> <th data-bbox="522 340 700 475" rowspan="2">AmpErase UNG Activation</th> <th data-bbox="700 340 877 475" rowspan="2">AmpliTag Gold DNA Polymerase Activation</th> <th colspan="2" data-bbox="877 340 1232 395">Each of 40 Cycles</th> </tr> <tr> <th data-bbox="877 395 1037 475">Melt</th> <th data-bbox="1037 395 1232 475">Anneal/Extend</th> </tr> </thead> <tbody> <tr> <td data-bbox="522 475 700 586">50 °C 2 min 100% ramp</td> <td data-bbox="700 475 877 586">94.5 °C 10 min 100% ramp</td> <td data-bbox="877 475 1037 586">97 °C 30 sec 50% ramp</td> <td data-bbox="1037 475 1232 586">59.7 °C 1 min 100% ramp</td> </tr> </tbody> </table>	AmpErase UNG Activation	AmpliTag Gold DNA Polymerase Activation	Each of 40 Cycles		Melt	Anneal/Extend	50 °C 2 min 100% ramp	94.5 °C 10 min 100% ramp	97 °C 30 sec 50% ramp	59.7 °C 1 min 100% ramp
AmpErase UNG Activation	AmpliTag Gold DNA Polymerase Activation			Each of 40 Cycles							
		Melt	Anneal/Extend								
50 °C 2 min 100% ramp	94.5 °C 10 min 100% ramp	97 °C 30 sec 50% ramp	59.7 °C 1 min 100% ramp								
6.	<p>Save the document or continue without saving, as explained in the following table:</p> <table border="1" data-bbox="522 713 1232 1216"> <thead> <tr> <th data-bbox="522 713 877 777">If you are running...</th> <th data-bbox="877 713 1232 777">Then...</th> </tr> </thead> <tbody> <tr> <td data-bbox="522 777 877 904">a single Micro Fluidic Card</td> <td data-bbox="877 777 1232 904">go to step 7. Alternatively, you can save the document for later use.</td> </tr> <tr> <td data-bbox="522 904 877 1216"> the first Micro Fluidic Card in a series with identical assay configurations Note: These instructions are for running Micro Fluidic Cards manually. For instructions on batch automation, refer to Chapter 6 of the user guide for the 7900HT system. </td> <td data-bbox="877 904 1232 1216"> 1. Save the Micro Fluidic Card document as an SDS template document (*.sdt). 2. Create a new Micro Fluidic Card document (*.sds) from the template. 3. Go to step 7. </td> </tr> </tbody> </table>	If you are running...	Then...	a single Micro Fluidic Card	go to step 7. Alternatively, you can save the document for later use.	the first Micro Fluidic Card in a series with identical assay configurations Note: These instructions are for running Micro Fluidic Cards manually. For instructions on batch automation, refer to Chapter 6 of the user guide for the 7900HT system.	1. Save the Micro Fluidic Card document as an SDS template document (*.sdt). 2. Create a new Micro Fluidic Card document (*.sds) from the template. 3. Go to step 7.				
If you are running...	Then...										
a single Micro Fluidic Card	go to step 7. Alternatively, you can save the document for later use.										
the first Micro Fluidic Card in a series with identical assay configurations Note: These instructions are for running Micro Fluidic Cards manually. For instructions on batch automation, refer to Chapter 6 of the user guide for the 7900HT system.	1. Save the Micro Fluidic Card document as an SDS template document (*.sdt). 2. Create a new Micro Fluidic Card document (*.sds) from the template. 3. Go to step 7.										
7.	<p>Enter the sample names. Sample names serve as keys to group samples for RQ analysis.</p>										
8.	<p>Continue with “Performing the Micro Fluidic Card Run” on page 26.</p>										

Additional Information About Creating SDS Templates and Documents

The user guide for the 7900HT system provides information about:

- Creating SDS documents and templates manually
- Creating SDS documents and templates for absolute quantification studies

Performing the Micro Fluidic Card Run

Before performing the run, place the Micro Fluidic Card in the 7900HT system as explained in the following procedure.

Note: The procedure assumes that you have imported the SDS setup file and created an appropriate Micro Fluidic Card SDS document. Refer to [“Creating Micro Fluidic Card Documents” on page 20](#) for more information. Incorrect setup can lead to erroneous analysis or loss of data.

To place the Micro Fluidic Card in the 7900HT system:

1.	In the SDS 2.1 software, open the Micro Fluidic Card document for the card you are running.
2.	Click the Instrument tab.
3.	In the Real-Time tab, click Open/Close . The instrument tray rotates to the OUT position.

To place the Micro Fluidic Card in the 7900HT system: (continued)

4. Use the barcode and the notched corner on the Micro Fluidic Card's carrier to determine the proper orientation of the Micro Fluidic Card for the 7900HT system.

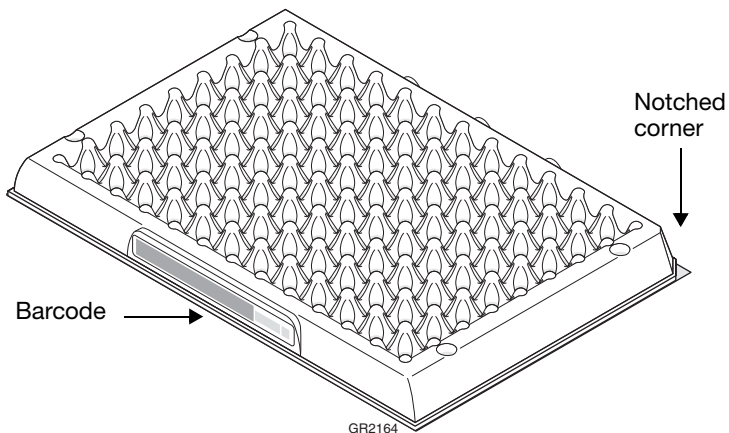

5. Place the Micro Fluidic Card into the 7900HT system as shown below.

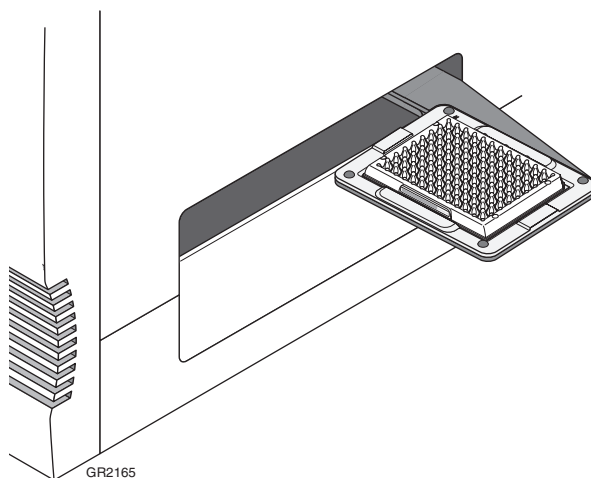

Once the card is properly loaded, save the document, then start and complete the run as follows:

To perform the run:

1.	<p>In the Real-Time tab of the SDS software, click Start.</p> <p>The 7900HT SDS begins the run. The time remaining until the end of the run is shown in the Real-Time tab under Time Remaining.</p> <p>Note: Before starting the run, the instrument may pause (up to 15 min) to heat the heated cover to the appropriate temperature.</p>
2.	<p>Remove the card from the 7900HT system when the run is complete and the Run Complete dialog box appears:</p> <ol style="list-style-type: none">a. Click OK to close the dialog box.b. Click Open/Close and remove the Micro Fluidic Card from the instrument.
3.	<p>If you need more information on starting and completing a run, refer to the user guide for the 7900HT system.</p>
4.	<p>Perform real-time data analysis as explained in “Performing Real-Time Data Analysis” on page 29.</p>

Performing Real-Time Data Analysis

Summary Real-time is the term used to describe the category of sequence detection runs in which the ABI PRISM® 7900HT Sequence Detection System is used to measure the fluorescence of a biological sample during thermal cycling. Real-time experiments can be used to achieve both qualitative and quantitative measurements.

Where You Are in the Procedure

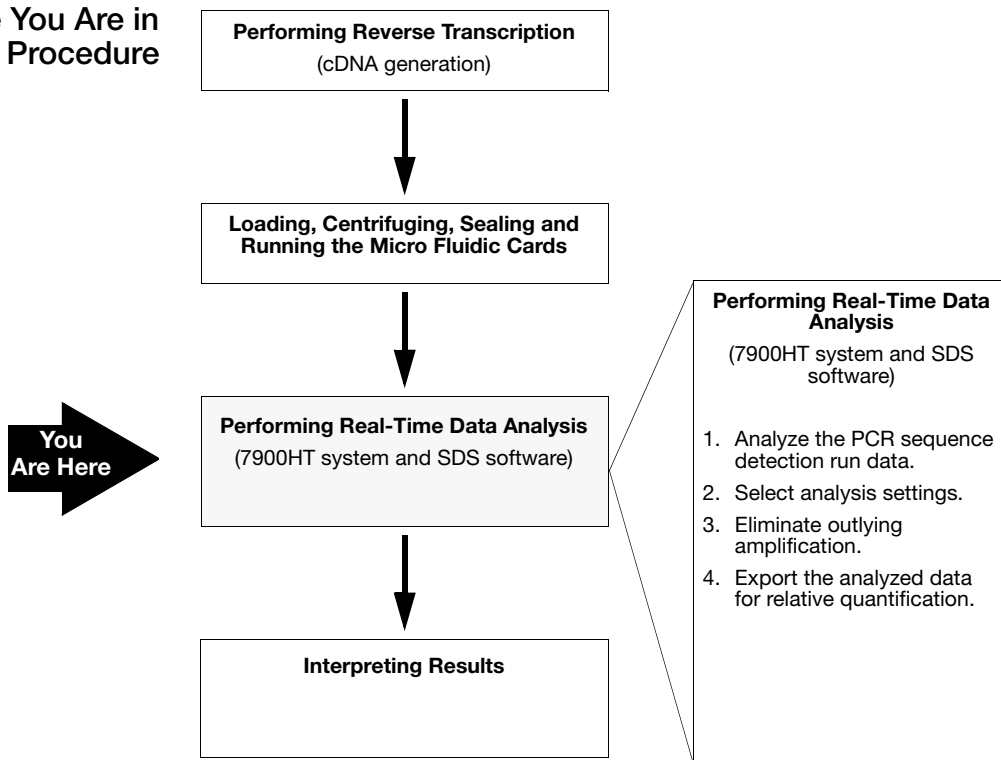

Absolute vs. Relative Quantification

When calculating the results of your quantification assays, you can use either relative or absolute quantification documents to perform relative quantification analysis. The type of document depends on whether you will use Applied Biosystems SDS 2.1 software or custom software to perform RQ analysis.

Relative quantification describes the change in expression of the target gene in a test sample relative to a calibrator sample. The calibrator sample can be an untreated control or a sample at time zero in a time-course study (Livak and Schmittgen, 2001). Relative quantification provides accurate comparison between the initial level of template in each sample.

For Micro Fluidic Card assays, relative quantification using the comparative C_T method is recommended.

The following documents provide more information about relative quantification:

- Livak, K.J., and Schmittgen, T.D., 2001. Analysis of Relative Gene Expression Data Using Real-Time Quantitative PCR and the $2^{-\Delta\Delta CT}$ Method. *Methods* 25:402-408.
- *ABI PRISM[®] 7700 Sequence Detection System User Bulletin #2: Relative Quantitation of Gene Expression* (PN 4303859)
- *ABI PRISM[®] 7900HT Sequence Detection Systems and SDS Enterprise Database User Guide* (PN 4317596)
- *Relative Quantification Quick Start: ABI PRISM[®] 7900HT Sequence Detection System Quick Reference Card* (PN 4342505)^a
- *RQ Manager Software User Guide* (PN 4339753)^a

a. Contact your Applied Biosystems sales representative to obtain a copy of this document.

Additional Tasks Related to Micro Fluidic Card Use

The following table lists additional tasks related to Micro Fluidic Card operation and references that provide details for accomplishing these tasks.

Task	Comment	Reference
Interpreting results	—	Chapter 6 of the user guide for the 7900HT system
Replacing the sample block	To run Micro Fluidic Cards on the 7900HT system, you must replace the existing sample block with the Micro Fluidic Card Sample Block (PN 4329011).	Chapter 7 of the user guide for the 7900HT system
Creating spectral calibration files	Perform background and pure dye runs regularly to ensure optimal Micro Fluidic Card performance.	Chapter 7 of the user guide for the 7900HT system
Verifying instrument performance using the AB 7900HT Installation Micro Fluidic Card	The AB 7900HT Installation Micro Fluidic Card is sometimes referred to as the TGF- β card.	Chapter 7 of the user guide for the 7900HT system
Troubleshooting Micro Fluidic Cards	—	Chapter 8 of the user guide for the 7900HT system

References

Kwok, S. and Higuchi, R. 1989. Avoiding false positives with PCR. *Nature* 339:237–238.

Livak, K.J., and Schmittgen, T.D., 2001. Analysis of Relative Gene Expression Data Using Real-Time Quantitative PCR and the $2^{-\Delta\Delta CT}$ Method. *Methods* 25:402-408.

Mullis, K.B. and Faloona, F. A.. 1987. Specific synthesis of DNA in vitro via a polymerase-catalyzed chain reaction. *Methods Enzymol.* 155:335–350.

Saiki, R.K., Scharf, S., Faloona, F., *et al.* 1985 Enzymatic amplification of β -globin genomic sequences and restriction site analysis for diagnosis of sickle cell anemia. *Science* 230:1350–1354.

Appendix A Micro Fluidic Card Information CD

About the Micro Fluidic Card Information CD

When you order a custom Micro Fluidic Card, you receive a Micro Fluidic Card Information CD along with your order. The CD contains the following files:

- Assay Information File (AIF)
- Card map files (2)
- SDS setup file
- `readme.txt`
- *Micro Fluidic Card Getting Started Guide* (PN 4319399 Rev. C)
- *ABI PRISM® 7900HT Sequence Detection System and SDS Enterprise Database User Guide* (PN 4317596 Rev. B)

This appendix describes the AIF, card map files, and SDS setup file.

Assay Information File

Function of AIFs

The Assay Information File (AIF) contains gene annotation information for the Micro Fluidic Card and for the assays that you ordered. The file is delivered in a text format, which can be used by several Applied Biosystems instruments, including the 7900HT.

Assay information file names take the following form:

`AIF_prodNum.txt`, where *prodNum* is the production number of the Micro Fluidic Card. For example, the assay information file for the card shown in [Figure 1 on page 36](#) is `AIF_143382.txt`.

Fields in an AIF

All assay information files for Micro Fluidic Cards contain the fields shown in the following table. The information is provided for each well in the card.

Note: AIFs contain other fields with information that may not apply to Micro Fluidic Cards. These fields (not included in the table) are marked N/A.

Field Name	Description
Customer Name	Customer's organization or institution.
Order Number	Customer sales order number.

Field Name	Description
Ship Date	Date the product is packaged for shipment.
Delivery Number	Unique number used for shipping.
Part Number	Part number of the assays on the card.
Product Type	Type of product, as indicated by the product number. For Micro Fluidic Cards, the product type is Assays-on-Demand™ Gene Expression Products.
Assay ID	Unique identifier for the assay.
Lot Number	Unique identifier for the manufacturing batch.
Plate Type	Container used for the assays (in this case, Micro Fluidic Card).
Well Location	Well location of the assay in the associated barcoded plate.
Assay Mix Conc.	Final concentration of the assay mix.
Forward Primer Conc.	Concentration (in μM) of the forward primer.
Reverse Primer Conc.	Concentration (in μM) of the reverse primer.
Reporter Dye 1	Dye label for the reporter for the assay.
Reporter 1 Conc.	Concentration (in μM) of Reporter 1.
Reporter 1 Quencher	Quencher used for Reporter 1 of the assay.
Context Sequence	Nucleotide sequence surrounding the probe.
Category	Category of the protein based on the Celera Panther Protein Classification, Level 1.
Category ID	Unique 10-digit ID of the category.

Field Name	Description
Group	Group of the protein based on the Celera Panther Protein Classification, Level 2.
Group ID	Unique 10-digit ID of the group.
Gene Symbol	LocusLink symbol for the associated gene.
Gene Name	LocusLink gene name.
Chromosome	Chromosome on which the gene or SNP is found.
Species	Organism for which the assay was designed.
Target Exons	The two exons (identified by public accession numbers) spanned by the probe.
NCBI Gene Reference	NCBI transcript ID detected by the assay.
Medline Reference	PubMed references for the gene.
Celera ID	Unique assay ID in the Celera Discovery System (CDS).
Cytogenic Band	Chromosomal band location of gene. If not available, the chromosome number is listed instead.

Viewing Contents of an AIF

To view the contents of an assay information file in Microsoft Excel as a spreadsheet:

1.	Place the Micro Fluidic Card Information CD in the CD drive (typically D: or E:).
2.	Launch Microsoft Excel.

To view the contents of an assay information file in Microsoft Excel as a spreadsheet: *(continued)*

3. Open the AIF.
 - a. From the File menu, select Open.
 - b. Navigate to the drive that contains the Micro Fluidic Card Information CD.
 - c. Select the AIF_*prodNum*.txt file and click Open.

Microsoft Excel displays the contents of the file in a spreadsheet.

Card Map Files

Card maps show the position of the assays on the Micro Fluidic Card. Each card map file contains two color-coded maps. The top map shows the replicate distribution gene symbol for each well. The bottom map shows the Applied Biosystems assay ID numbers.

Athena Microcard configuration: 3 (4342251)

Production Number: 143382

Gene Symbols

1	2	3	4	5	6	7	8	9	10	11	12	13	14	15	16	17	18	19	20	21	22	23	24	
1	IL10	IL10	TGF2	TGF2	CD86	CD86	IL8	IL8	FGF2	FGF2	4342376-GAPDH	4342376-GAPDH	EGR1	EGR1	CSF2	CSF2	IL12B	IL12B	TNF	TNF	CD83	CD83	COL1A2	COL1A2
2	IL10	IL10	TGF2	TGF2	CD86	CD86	IL8	IL8	FGF2	FGF2	4342376-GAPDH	4342376-GAPDH	EGR1	EGR1	CSF2	CSF2	IL12B	IL12B	TNF	TNF	CD83	CD83	COL1A2	COL1A2
3	IFNB1	IFNB1	IFNA2	IFNA2	IL2RA	IL2RA	CD44	CD44	MMP1	MMP1	MMP3	MMP3	IFNG	IFNG	FGF7	FGF7	TGF2	TGF2	COL6A1	COL6A1	TIMP3	TIMP3	TIMP1	TIMP1
4	IFNB1	IFNB1	IFNA2	IFNA2	IL2RA	IL2RA	CD44	CD44	MMP1	MMP1	MMP3	MMP3	IFNG	IFNG	FGF7	FGF7	TGF2	TGF2	COL6A1	COL6A1	TIMP3	TIMP3	TIMP1	TIMP1
5	IL10	IL10	TGF2	TGF2	CD86	CD86	IL8	IL8	FGF2	FGF2	4342376-GAPDH	4342376-GAPDH	EGR1	EGR1	CSF2	CSF2	IL12B	IL12B	TNF	TNF	CD83	CD83	COL1A2	COL1A2
6	IL10	IL10	TGF2	TGF2	CD86	CD86	IL8	IL8	FGF2	FGF2	4342376-GAPDH	4342376-GAPDH	EGR1	EGR1	CSF2	CSF2	IL12B	IL12B	TNF	TNF	CD83	CD83	COL1A2	COL1A2
7	IFNB1	IFNB1	IFNA2	IFNA2	IL2RA	IL2RA	CD44	CD44	MMP1	MMP1	MMP3	MMP3	IFNG	IFNG	FGF7	FGF7	TGF2	TGF2	COL6A1	COL6A1	TIMP3	TIMP3	TIMP1	TIMP1
8	IFNB1	IFNB1	IFNA2	IFNA2	IL2RA	IL2RA	CD44	CD44	MMP1	MMP1	MMP3	MMP3	IFNG	IFNG	FGF7	FGF7	TGF2	TGF2	COL6A1	COL6A1	TIMP3	TIMP3	TIMP1	TIMP1
9	IL10	IL10	TGF2	TGF2	CD86	CD86	IL8	IL8	FGF2	FGF2	4342376-GAPDH	4342376-GAPDH	EGR1	EGR1	CSF2	CSF2	IL12B	IL12B	TNF	TNF	CD83	CD83	COL1A2	COL1A2
10	IL10	IL10	TGF2	TGF2	CD86	CD86	IL8	IL8	FGF2	FGF2	4342376-GAPDH	4342376-GAPDH	EGR1	EGR1	CSF2	CSF2	IL12B	IL12B	TNF	TNF	CD83	CD83	COL1A2	COL1A2
11	IFNB1	IFNB1	IFNA2	IFNA2	IL2RA	IL2RA	CD44	CD44	MMP1	MMP1	MMP3	MMP3	IFNG	IFNG	FGF7	FGF7	TGF2	TGF2	COL6A1	COL6A1	TIMP3	TIMP3	TIMP1	TIMP1
12	IFNB1	IFNB1	IFNA2	IFNA2	IL2RA	IL2RA	CD44	CD44	MMP1	MMP1	MMP3	MMP3	IFNG	IFNG	FGF7	FGF7	TGF2	TGF2	COL6A1	COL6A1	TIMP3	TIMP3	TIMP1	TIMP1
13	IL10	IL10	TGF2	TGF2	CD86	CD86	IL8	IL8	FGF2	FGF2	4342376-GAPDH	4342376-GAPDH	EGR1	EGR1	CSF2	CSF2	IL12B	IL12B	TNF	TNF	CD83	CD83	COL1A2	COL1A2
14	IL10	IL10	TGF2	TGF2	CD86	CD86	IL8	IL8	FGF2	FGF2	4342376-GAPDH	4342376-GAPDH	EGR1	EGR1	CSF2	CSF2	IL12B	IL12B	TNF	TNF	CD83	CD83	COL1A2	COL1A2
15	IFNB1	IFNB1	IFNA2	IFNA2	IL2RA	IL2RA	CD44	CD44	MMP1	MMP1	MMP3	MMP3	IFNG	IFNG	FGF7	FGF7	TGF2	TGF2	COL6A1	COL6A1	TIMP3	TIMP3	TIMP1	TIMP1
16	IFNB1	IFNB1	IFNA2	IFNA2	IL2RA	IL2RA	CD44	CD44	MMP1	MMP1	MMP3	MMP3	IFNG	IFNG	FGF7	FGF7	TGF2	TGF2	COL6A1	COL6A1	TIMP3	TIMP3	TIMP1	TIMP1

Assay IDs

1	2	3	4	5	6	7	8	9	10	11	12	13		
1	Hs00174086_m1	Hs00174086_m1	Hs00234244_m1	Hs00234244_m1	Hs00199349_m1	Hs00199349_m1	Hs00174103_m1	Hs00174103_m1	Hs00266645_m1	Hs00266645_m1	4342376-GAPDH	4342376-GAPDH	Hs00152928_m1	Hs00152928_m1
2	Hs00174086_m1	Hs00174086_m1	Hs00234244_m1	Hs00234244_m1	Hs00199349_m1	Hs00199349_m1	Hs00174103_m1	Hs00174103_m1	Hs00266645_m1	Hs00266645_m1	4342376-GAPDH	4342376-GAPDH	Hs00152928_m1	Hs00152928_m1
3	Hs00277188_s1	Hs00277188_s1	Hs00265051_s1	Hs00265051_s1	Hs00166229_m1	Hs00166229_m1	Hs00174139_m1	Hs00174139_m1	Hs00233958_m1	Hs00233958_m1	Hs00233962_m1	Hs00233962_m1	Hs00174145_m1	Hs00174145_m1
4	Hs00277188_s1	Hs00277188_s1	Hs00265051_s1	Hs00265051_s1	Hs00166229_m1	Hs00166229_m1	Hs00174139_m1	Hs00174139_m1	Hs00233958_m1	Hs00233958_m1	Hs00233962_m1	Hs00233962_m1	Hs00174145_m1	Hs00174145_m1
5	Hs00174086_m1	Hs00174086_m1	Hs00234244_m1	Hs00234244_m1	Hs00199349_m1	Hs00199349_m1	Hs00174103_m1	Hs00174103_m1	Hs00266645_m1	Hs00266645_m1	4342376-GAPDH	4342376-GAPDH	Hs00152928_m1	Hs00152928_m1
6	Hs00174086_m1	Hs00174086_m1	Hs00234244_m1	Hs00234244_m1	Hs00199349_m1	Hs00199349_m1	Hs00174103_m1	Hs00174103_m1	Hs00266645_m1	Hs00266645_m1	4342376-GAPDH	4342376-GAPDH	Hs00152928_m1	Hs00152928_m1
7	Hs00277188_s1	Hs00277188_s1	Hs00265051_s1	Hs00265051_s1	Hs00166229_m1	Hs00166229_m1	Hs00174139_m1	Hs00174139_m1	Hs00233958_m1	Hs00233958_m1	Hs00233962_m1	Hs00233962_m1	Hs00174145_m1	Hs00174145_m1
8	Hs00277188_s1	Hs00277188_s1	Hs00265051_s1	Hs00265051_s1	Hs00166229_m1	Hs00166229_m1	Hs00174139_m1	Hs00174139_m1	Hs00233958_m1	Hs00233958_m1	Hs00233962_m1	Hs00233962_m1	Hs00174145_m1	Hs00174145_m1
9	Hs00174086_m1	Hs00174086_m1	Hs00234244_m1	Hs00234244_m1	Hs00199349_m1	Hs00199349_m1	Hs00174103_m1	Hs00174103_m1	Hs00266645_m1	Hs00266645_m1	4342376-GAPDH	4342376-GAPDH	Hs00152928_m1	Hs00152928_m1
10	Hs00174086_m1	Hs00174086_m1	Hs00234244_m1	Hs00234244_m1	Hs00199349_m1	Hs00199349_m1	Hs00174103_m1	Hs00174103_m1	Hs00266645_m1	Hs00266645_m1	4342376-GAPDH	4342376-GAPDH	Hs00152928_m1	Hs00152928_m1
11	Hs00277188_s1	Hs00277188_s1	Hs00265051_s1	Hs00265051_s1	Hs00166229_m1	Hs00166229_m1	Hs00174139_m1	Hs00174139_m1	Hs00233958_m1	Hs00233958_m1	Hs00233962_m1	Hs00233962_m1	Hs00174145_m1	Hs00174145_m1
12	Hs00277188_s1	Hs00277188_s1	Hs00265051_s1	Hs00265051_s1	Hs00166229_m1	Hs00166229_m1	Hs00174139_m1	Hs00174139_m1	Hs00233958_m1	Hs00233958_m1	Hs00233962_m1	Hs00233962_m1	Hs00174145_m1	Hs00174145_m1
13	Hs00174086_m1	Hs00174086_m1	Hs00234244_m1	Hs00234244_m1	Hs00199349_m1	Hs00199349_m1	Hs00174103_m1	Hs00174103_m1	Hs00266645_m1	Hs00266645_m1	4342376-GAPDH	4342376-GAPDH	Hs00152928_m1	Hs00152928_m1

Figure 1 Sample HTML card map file viewed in a browser

Card map files also indicate the

- Micro Fluidic Card Configuration and part number. In [Figure 1](#) above, the card uses Configuration 3, which has a part number of 4342251.
- Production Number of the card. Each custom Micro Fluidic Card is assigned a unique production number. This number appears as part of the file names of AIF, cardmap, and SDS setup files. In [Figure 1](#) above, the production number of the card is 143382.

Each Micro Fluidic Card Information CD contains two card map files, one in HTML format, and the other in spreadsheet format.

Card Map Files in HTML Format

The `prodNum_cardmap.html` file contains the card map for your custom Micro Fluidic Card in HTML format. For example, `143382.cardmap.html` is the name of the HTML card map file in [Figure 1 on page 36](#).

Open the HTML card map when you want to view the map in a browser.

Card Map Files in Spreadsheet Format

The `prodNum_cardmap.xls` contains the card map for your custom Micro Fluidic Card as a Microsoft Excel spreadsheet. For example, `143382.cardmap.xls` is the name of the Excel spreadsheet for the card map file in [Figure 1 on page 36](#).

Open the card map file as a spreadsheet when you want to print the card map on one page.

SDS Setup File

The SDS setup file contains information specific to your Micro Fluidic Card, such as detector/reporter and task for each well. You can import this file to create SDS documents or templates, as explained in [“Creating Micro Fluidic Card Documents” on page 20](#).

The SDS setup file is shipped in text format, `SDS_prodNum.txt`. For example, the setup file for the card shown in [Figure 1](#) is `SDS_143382.txt`.

IMPORTANT! Modifying the contents of the file can corrupt the information on the Micro Fluidic Card.

Once you have imported the setup file into an SDS document, the SDS 2.1 software assigns the detectors for each assay to the appropriate wells as indicated in the card map.

Figure 2 shows an SDS document after an SDS setup file has been imported.

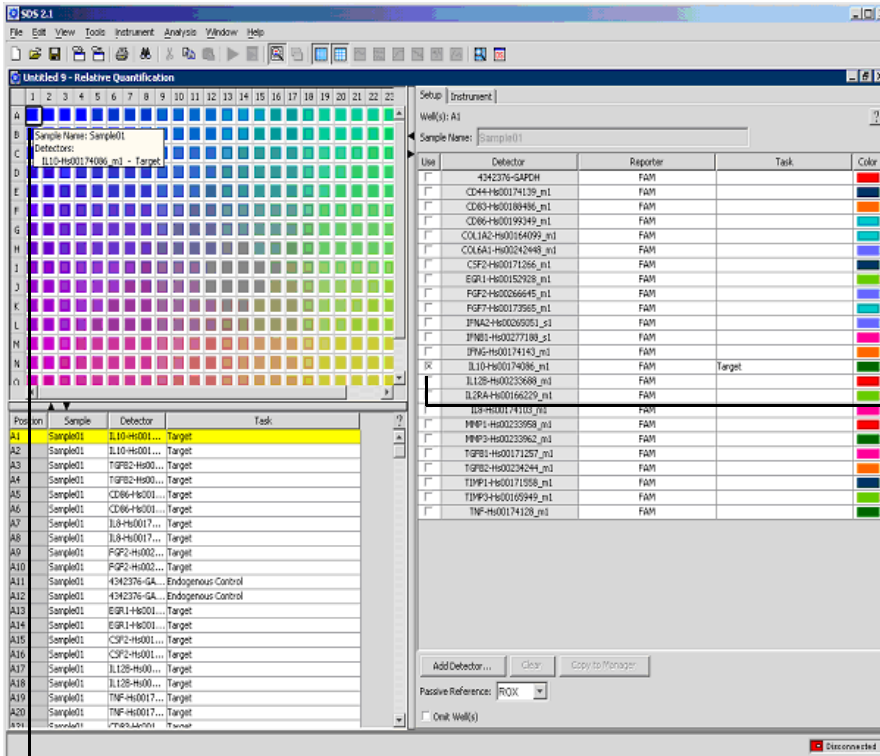

Setup tab displays information about each well. Selected wells are marked with an X.

SDS 2.1 software displays well information if you leave the cursor over the well

Figure 2 SDS document after importing an SDS setup file

Index

A

- absolute quantification 30
- AIF. *See* Assay Information Files
- analyzing data
 - document type, selecting 12
 - real-time analysis 29
 - relative quantification 30
- assay ID map 36
- Assay Information Files
 - fields for Micro Fluidic Cards 33
 - function 33
 - viewing as spreadsheet 35
- Assays-on-Demand 4

C

- calibration files, spectral 31
- calibrator sample 12
- card map files
 - function 36
 - HTML format 37
 - information in 36
 - opening as a spreadsheet 37
 - opening in a browser 37
 - spreadsheet format 37
- Caution, definition 1
- cDNA
 - amount for PCR 17
 - per-port-amount guidelines 14
 - storing 14
- centrifuges
 - guidelines for operating 19
 - loading Micro Fluidic Cards in 19
 - maximum speed 19
 - rotors, compatible 10
 - supported models 10
- chemical installation kit 7
- chemistry, Micro Fluidic Card 5

- Comparative C_T Method for relative quantification 12
- conditions, storage and shipping 7
- configurations, Micro Fluidic Card 8
- contamination, preventing 5

D

- Danger, definition 1
- data, analysis of 12
- detectors 5
- documentation 30
- documents
 - conversion between AQ and RQ 12
 - creating 20
 - information contained in 20
 - Micro Fluidic Card 20
 - plate 12
 - references, additional 26
 - SDS 20, 38
 - SDS setup file. *See* SDS setup file
 - templates 20

E

- equipment, Micro Fluidic Card experiments for 7
- experiments
 - calibrator sample 12
 - design guidelines 12
 - process overview 6
 - required materials and equipment 7

F

- features of Micro Fluidic Cards 4
- flowchart, process 6

-
- G**
gene symbol map 36
- H**
hardware upgrade kit 7
High Capacity cDNA Archive Kit 13
- I**
Immune Profiling Micro Fluidic Card 9
Important, definition 1
interpreting results 31
- L**
loading Micro Fluidic Cards 19
- M**
map, card 36
materials, Micro Fluidic Card experiments for 7
Micro Fluidic Card Information CD 33
Micro Fluidic Card kits
 chemical installation 7
 components 7
 hardware upgrade 7
MSDSs 2
- N**
number, production 37
- O**
overview, Micro Fluidic Card process 6
- P**
PCR
 guidelines for preparing reactions 17
 preparing sample-specific mix 17
 process overview 16
 running Micro Fluidic Cards 26
 starting amount of cDNA 17
 PCR (*continued*)
 summary of use in Micro Fluidic Card experiments 15
preparing Micro Fluidic Cards. *See* PCR
preventing contamination 5
process flowchart 6
production number of Micro Fluidic Cards 37
- Q**
quantification
 absolute 30
 relative 30
- R**
references, additional 30
relative quantification 30
replacing the sample block 31
results, interpreting 31
reverse transcription 13
RNA
 guidelines for sample preparation 14
 starting amount of total RNA 14
rotors 10
running Micro Fluidic Cards 26
- S**
Safety alerts, definitions 1
sample block, replacing 31
sample, calibrator 12
SDS documents 20
SDS setup file
 function 37
 importing 21
 use in generating documents and templates 21
setup file. *See* SDS setup file 21
shipping conditions 7
spectral calibration files 31
storage conditions 7
structure of Micro Fluidic Cards 5

T

templates, SDS [20](#)

TGF- β cards [31](#)

troubleshooting Micro Fluidic Cards [31](#)

V

verifying 7900HT performance using Micro
Fluidic Cards [31](#)

W

Warning, definition [1](#)

Waste disposal, guidelines [3](#)



Headquarters

850 Lincoln Centre Drive
Foster City, CA 94404 USA
Phone: +1 650.638.5800
Toll Free (In North America): +1 800.345.5224
Fax: +1 650.638.5884

Worldwide Sales and Support

Applied Biosystems vast distribution and service network, composed of highly trained support and applications personnel, reaches 150 countries on six continents. For sales office locations and technical support, please call our local office or refer to our Web site at www.appliedbiosystems.com.

www.appliedbiosystems.com



Applera Corporation is committed to providing the world's leading technology and information for life scientists. Applera Corporation consists of the Applied Biosystems and Celera Genomics businesses.

Printed in USA, 07/2003
Part Number 4319399 Rev. C

an **Applera** business